

Anderson, McLaren & Bryant,

Making Rope Molding.

No. 16,108,

Patented Nov. 25, 1856.

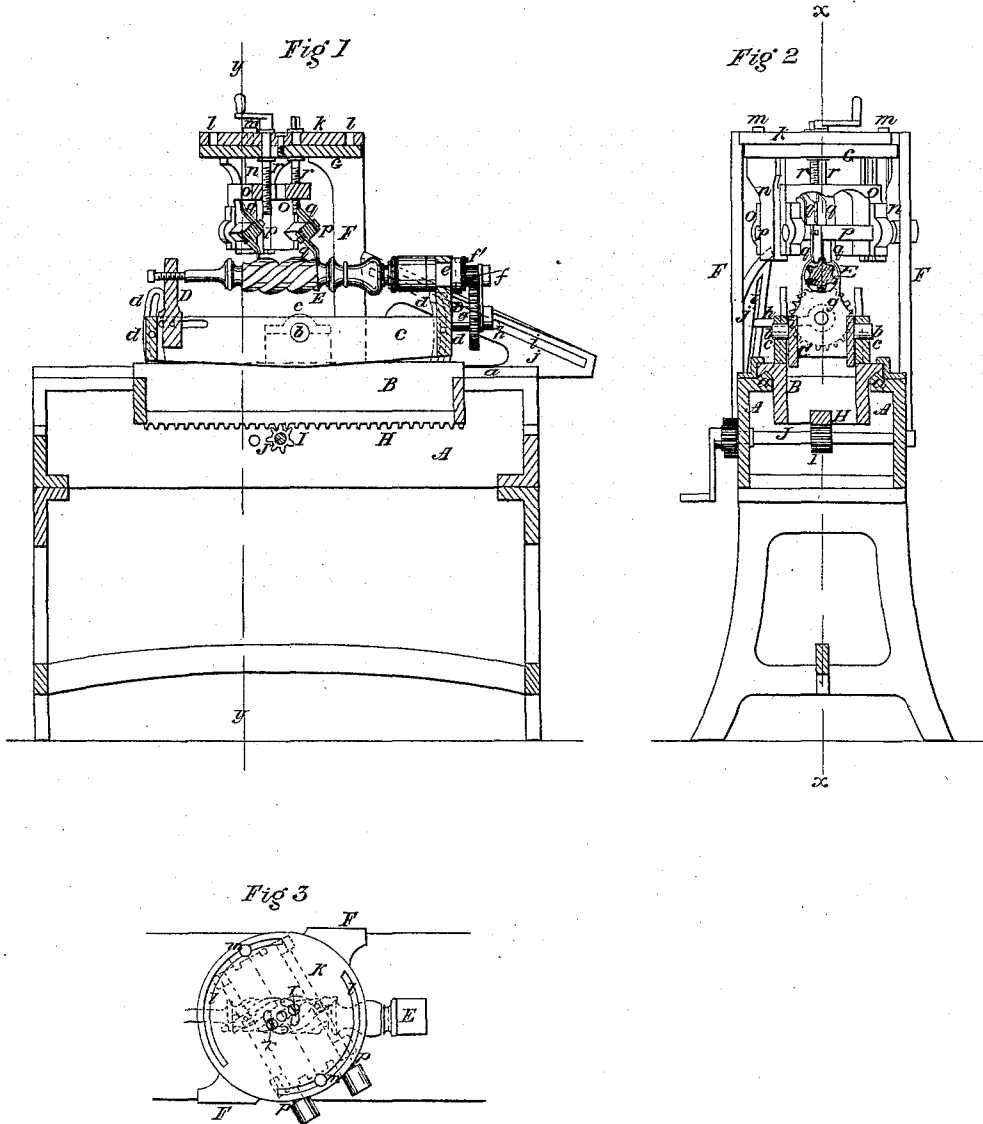

UNITED STATES PATENT OFFICE.

J. ANDERSON, J. McLAREN, AND J. BRYANT, OF NEW YORK, N. Y.

LATHE FOR CUTTING FLUTED MOLDINGS.

Specification of Letters Patent No. 16,108, dated November 25, 1856.

To all whom it may concern:

Be it known that we, JAMES ANDERSON, JOHN McLAREN, and JOHN BRYANT, of the city, county, and State of New York, have invented a new and useful Machine for Cutting Spiral Flutes on Furniture-Legs and other Cylindrical or Conical Shaped Articles; and we do hereby declare that the following is a full, clear, and exact description of the same, reference being had to the annexed drawing, making a part of this specification, in which—

Figure 1 is a longitudinal vertical section of our improvements, (*x*) (*x*) Fig. 2 showing the plane of section. Fig. 2 is a transverse vertical section of ditto (*y*) (*y*) Fig. 1 showing the plane of section. Fig. 3 is a plan or top view of the frame to which the cutters are secured.

Similar letters of reference indicate corresponding parts in the several figures.

Our invention consists in the employment or use of adjustable rotary cutters rotating in reverse directions and also in the employment or use of an adjustable reciprocating carriage in which the article to be fluted is centered, the article being turned or rotated between its centers by means of a guide block lever and gearing as will be presently shown and described whereby spiral flutes may be cut in an expeditious and perfect manner.

To enable those skilled in the art to fully understand and construct our invention, we will proceed to describe it.

A A represent two parallel beams which are placed on a proper framing or support. These beams have each a way or guide (*a*) on them, and B is a carriage which is fitted and works on said ways or guides.

C is a rectangular frame or box which has a journal (*b*) at each side, said journals being fitted in bearings (*c*) attached to the carriage B. The journals (*b*) are at the center portion of the frame or box and the ends of the frame or box are fitted between curved slotted uprights (*d*) attached to the ends of the carriage, said uprights having set screws (*d'*) passing through them and into the ends of the box or frame. At each end of the box or frame C there is placed a head D through which center points pass and between which the leg E or other article to be fluted is centered similar to the way in which articles are centered in a turning lathe. The shaft or arbor of one center point has a circular disk

(*e*) attached to it and a pinion (*f*) is placed loosely on the arbor or shaft of said point, said pinion gearing into a toothed wheel (*g*) which is fitted on a shaft attached to the outer side of one of the heads D. The wheel (*g*) has a lever (*h*) attached to it, the center end of which is fitted in an inclined slot (*i*) made in a ledge or plate (*j*) attached to one of the beams A.

The pinion (*f*) may be connected with the disk (*e*) by means of a pin *f'* which passes through a projection on said pinion and which is fitted in either of a series of holes made in the disk (*e*).

F, F, represent two uprights which are attached to the beams A, A. These uprights are connected at their upper ends by a circular plate (*k*) which has two segment slots (*l*) (*l*) made through it near its edge at opposite sides of its center.

G represents a circular block which is secured underneath the plate (*k*) by set screws (*m*) (*m*) which pass through the slots (*l*) (*l*). The block G has two pendants (*n*) (*n*) attached to it at opposite sides of its center said pendants forming guides for frames (*o*) (*o*) in which shafts (*p*) (*p*) are placed one in each frame. To each shaft two cutters (*q*), (*q*), are attached. These shafts are made to rotate in reverse directions by a cross belt or by any proper gearing. The frames (*o*) (*o*) may be raised and lowered by means of screw rods (*r*) (*r*) which pass through the plate (*k*) block G and frames (*o*) (*o*).

From the above description of parts it will be seen that the cutters may be raised and lowered and also turned around obliquely with the leg E. The block G being secured at any desired point by the set screws (*m*) (*m*).

The carriage B has a rack H attached to its under side and I is a pinion which gears into said rack, the pinion I being on a shaft J. By turning the shaft J back and forth by hand or otherwise a reciprocating motion is given the leg E and the leg is turned a certain distance at each vibration of the carriage B. One set of cutters cut a half flute, and the other set of cutters cut the opposite side of the flute and as the two sets of cutters rotate in reverse directions both sets will cut with the grain of the wood and the flutes will be cut in spiral form upon the leg E owing to the rotating motion given it by the lever, (*h*), working in the

inclined slot (*i*). When one flute is cut the leg E is turned around a certain distance and attached to the pinion (*f*) by the pin (*f'*).

The above invention is extremely simple, may be operated with facility, and the legs may be either of cylindrical or taper form, as the legs may be adjusted either in a horizontal or inclined position and the cutters may also be adjusted to suit the diameter of the leg and also the direction or curve of the flutes.

Having thus described our invention what we claim as new and desire to secure by Letters Patent, is—

15 1. The adjustable rotating cutters (*q*) (*q*) attached to shafts (*p*) (*p*) which are fitted in frames (*o*) (*o*) the frames being fitted and working in pendent guides (*n*) (*n*) at-

tached to the adjustable block G substantially as described for the purpose specified. 20

2. We claim placing the leg E between centers which are attached to a swinging frame C fitted on a reciprocating carriage B the leg being turned or rotated between its centers as the carriage moves by means 25 of the inclined slot (*i*) in the ledge or plate (*j*) and the lever (*h*) and gearing (*f'*) (*g*) as described.

JAMES ANDERSON.
JOHN McLAREN.
JOHN BRYANT.

Witnesses:

W. TUSCH,
JAMES F. BUCKLEY,
J. W. COOMBS.